

An Automatic Antenna Tuner: The AT-11

This easy-to-build, fully automatic tuner makes time-consuming knob twisting and roller cranking a page in your station's history book!

By Dwayne L. Kincaid, WD8OYG

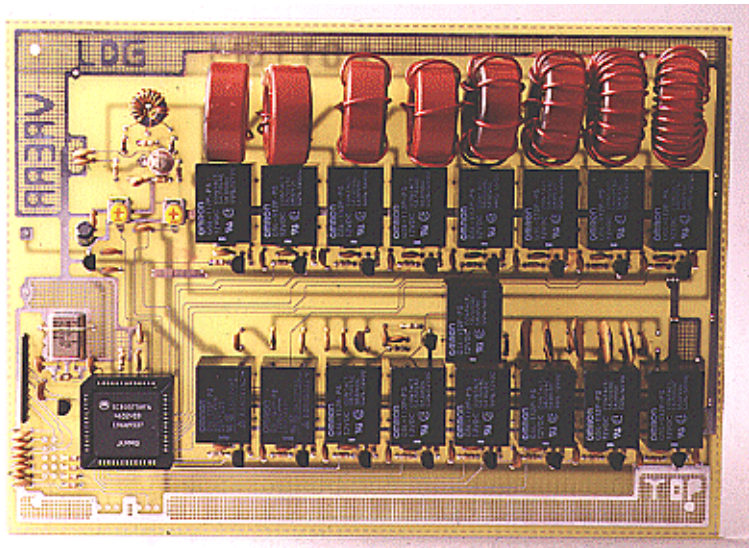

Merge a modern microprocessor with the time-proven L network and what do you get? The AT-11 antenna tuner. A 68HC11 microprocessor analyzes the SWR and makes inductance and capacitance adjustments faster than your hands can move a variable capacitor and roller inductor! Built on a 5-1/2 × 8-inch PC board, the AT-11 can handle 100 W continuously while matching most unbalanced (coax-fed) antennas on the 80 to 10-meter bands and some on 160. This tuner is a great addition to any ham shack equipped with a 2 to 100-W MF/HF transceiver—the AT-11 *does not require* band or frequency data from the radio. PC boards, *programmed* microprocessors and complete kits are available to make this project fit just about anyone's construction abilities. [1]

The AT-11 has two modes: automatic and semiautomatic. In the AUTO mode, the tuner automatically starts tuning if the SWR goes above 3. In the SEMI mode, the tuner seeks a match only when the TUNE pushbutton is pressed. In either case, the transmitter must supply an output power above 2 W while the tuner seeks a match. The AT-11 also has manual UP and DOWN inductor and capacitor controls for fine tuning.

Circuit Description

The block diagram of **Figure 1** shows the tuner's circuit (see **Figure 2**) broken into four sections: the SWR sensor, the LC networks, the microprocessor and the user interface.

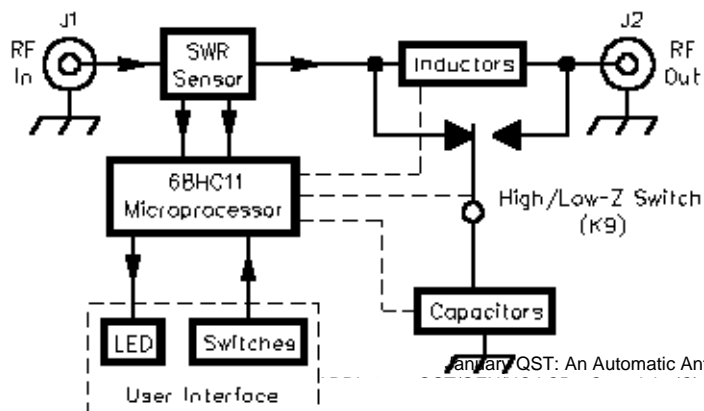

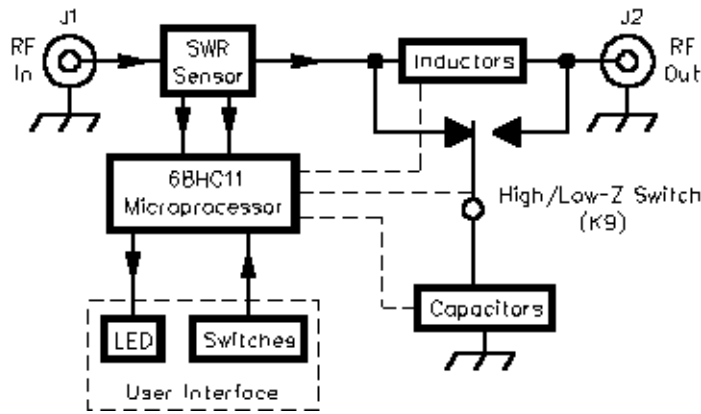
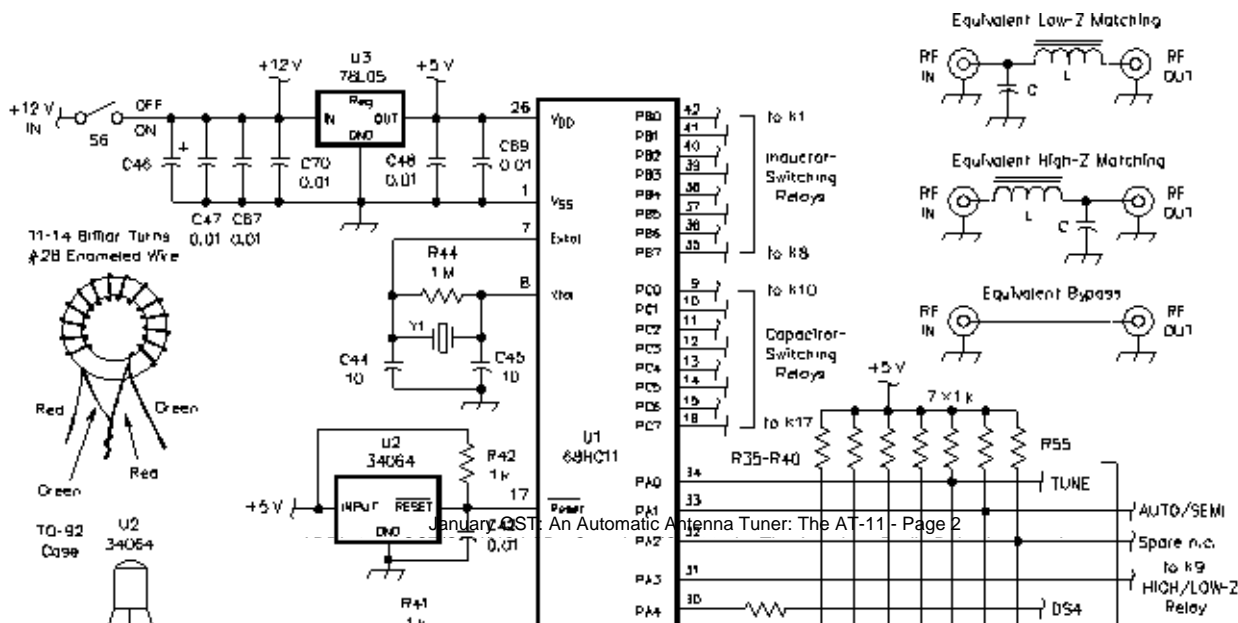
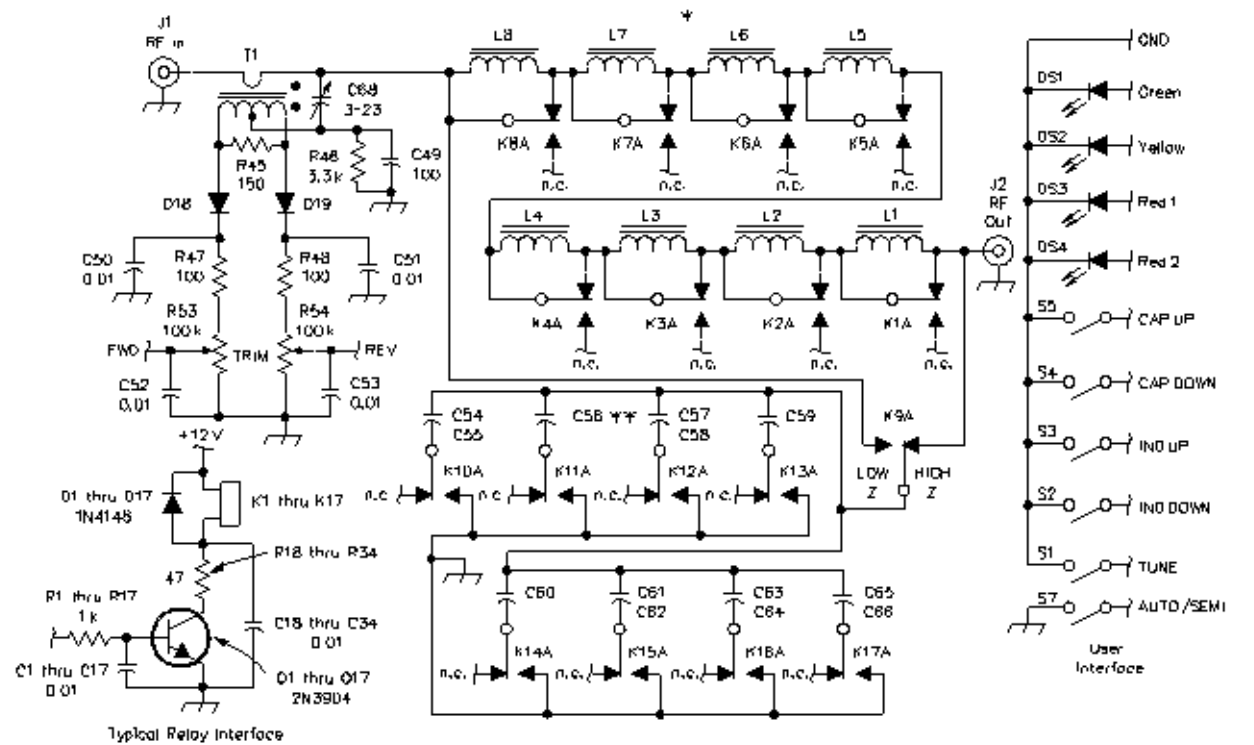

Figure 1—Block diagram of the automatic antenna tuner.



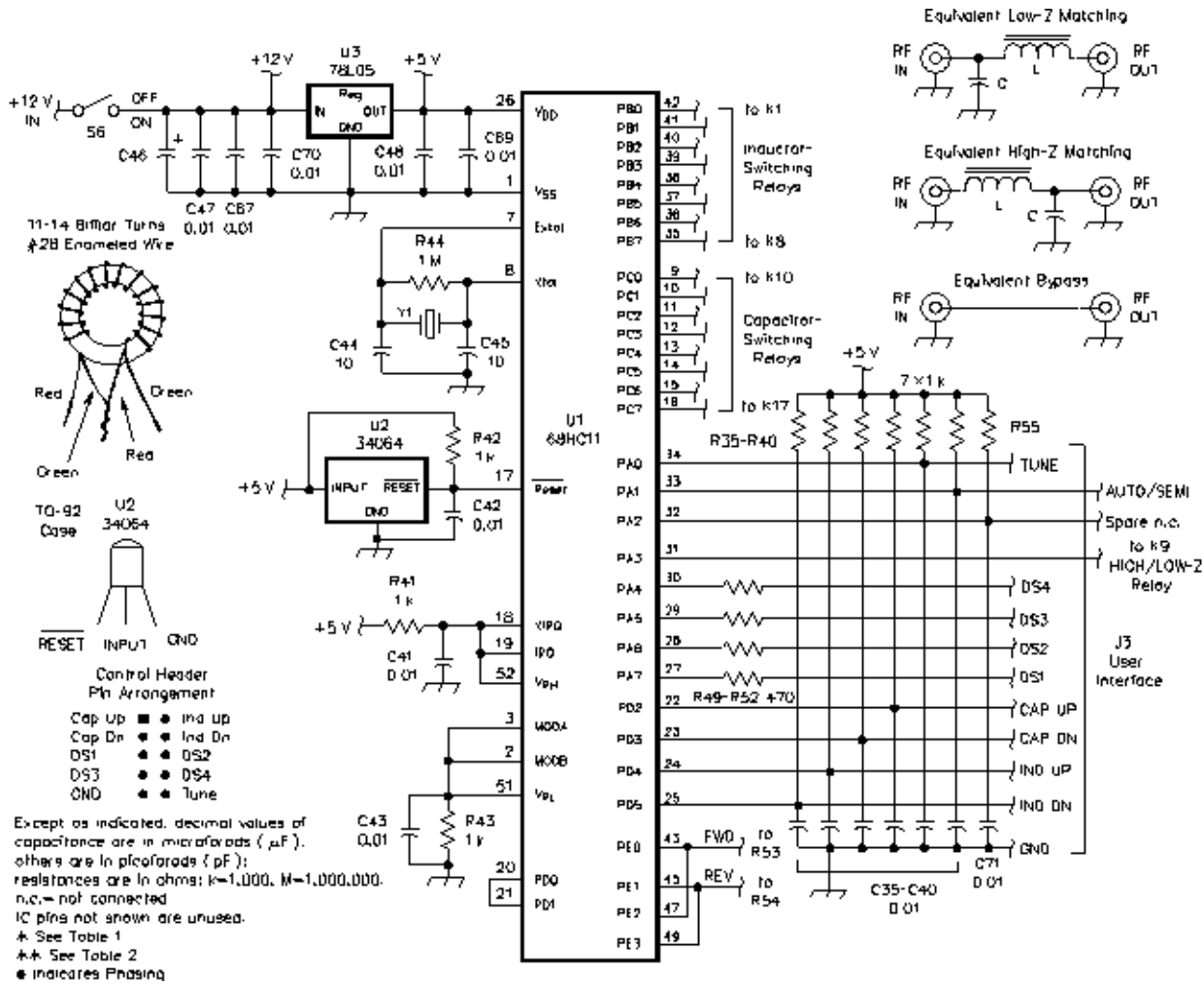

Figure 2—Schematic of the automatic antenna tuner. Equivalent parts can be substituted. Unless otherwise specified, resistors are 1/8-W, 5%-tolerance carbon-composition or film units; capacitors are 500-V units.

C44, C45—10-pF, 50-V silver mica

C46—10- μF , 50-V electrolytic or tantalum

C68—3 to 23-pF air-variable trimmer

D1-D19—1N4148 or 1N914

DS1—Green 5-mm LED

DS2—Yellow 5-mm LED

DS3, DS4—Red 5-mm LED

J1, J2—SO-239

K1-K17—SPDT relay, 12-V coil, 5-A contact rating (Omron G5L-112-PC-DC12)

L1-L8—T-106-2 toroid; see Table 1 for coil-winding information

Q1-Q17—2N3904

R35-R42—1-k Ω 10-pin SIP

R53, R54—100-k Ω trimmer potentiometer

S1-S5—Momentary contact, push-button switch

S6, S7—SPST toggle switch

T1—14 bifilar turns of #28 enameled wire wound on an FT-37-43 toroid

U1—68HC11A1FN *programmed* microcontroller; see Note 1

U2—34064-5P undervoltage sensing circuit

U3—78L05 5-V, 100-mA voltage regulator

Y1—4.433619 MHz

Misc: #18 and #28 enameled wire; 52-pin PLCC IC socket; enclosure; hardware

SWR sensor

The SWR sensor is a variation of the Bruene circuit. [2] This SWR measuring technique is used in most dual-meter and direct-reading SWR meters. Slight modifications were made to the circuit to provide voltages (instead of currents) for the analog-to-digital converters (ADCs) that are proportional to the forward and reverse power levels. The single-lead primary through the center of the T1 provides RF current sampling to the secondary. D18 and D19 rectify the sample and provide a dc voltage. R53 and R54 adjust the FORWARD and REVERSE power sensitivity. Once adjusted, the forward and reverse power sensors indicate 4.5 V dc at a power level of 100 W. These two voltages are read by the ADCs in the 68HC11. Once in a digital format, the forward and reverse voltage values are used to calculate SWR.

The Tuner

The tuner is a standard switchable L network consisting of a series inductor and parallel capacitor found in many tuner designs. I chose the L network for its minimum number of parts and its ability to tune unbalanced loads, such as coax-fed dipoles, verticals, Yagis, and similar antennas. [3]

Using eight toroidal inductors (see **Table 1**), the total inductance ranges from 0 to 20 μH . Each inductor's value is selected to provide 256 different combinations, with a resolution of 0.08 μH . The inductors are switched in and out of the circuit by relays (K1 through K8) which are controlled by the microprocessor.

The inductors are wound with #18 wire on T-106-2 forms. The -2 material was chosen to cover the HF range most efficiently and the -106 toroid size was selected for its power-handling capabilities. The #18 wire was chosen for its 10-A rating. Smaller toroids and smaller wire could be used at low power levels. For example, the popular T-50-2 toroid handles about 40 W continuously.

Using eight 500-V capacitors, the total capacitance ranges from 0 to 1280 pF. Each capacitor's value is selected to provide 256 combinations, with a resolution of 5 pF (see **Table 2**). The capacitors are connected to ground in parallel with the inductor by relays K10 through K17.

K9 switches the entire capacitor bank to the input or output side of the inductor. This switching allows the AT-11 to automatically handle loads that are greater than 50 Ω (HIGH) and less than 50 Ω (LOW); see the inset of **Figure 1**. With the 17 relays, there are 131,072 inductor and capacitor combinations ($256 \times 256 \times 2$). All of the relays are SPDT 12-V dc types that draw about 30 mA each when energized and whose contacts can handle 5 A at 250 V.

Table 1—L-Network Inductor Information

| Inductor No. | Target Value (μH) | Actual Value (μH) | No. of Turns on T-106-2 Toroid | Wire Length Needed (inches) |
|--------------|--------------------------------|--------------------------------|--------------------------------|-----------------------------|
| L1 | 0.08 | 0.11 | 1 (bottom) | 2 |
| L2 | 0.16 | 0.22 | 2 (bottom) | 4 |
| L3 | 0.31 | 0.39 | 3 | 8 |
| L4 | 0.62 | 0.59 | 4 | 9 |
| L5 | 1.25 | 1.25 | 7 | 15 |
| L6 | 2.5 | 2.5 | 11 | 20 |
| L7 | 5.0 | 5.0 | 17 | 30 |
| L8 | 10 | 10 | 25 | 40 |

Note: All inductors wound with #18 enameled wire.

L3-L8 (L5 shown)

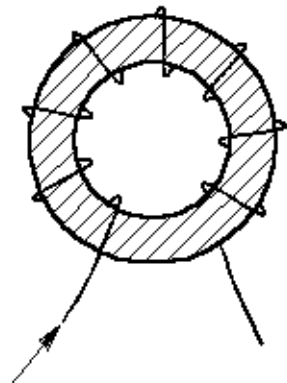

Start here. Leave 1" Lead Length

L1-L2 (L2 shown)

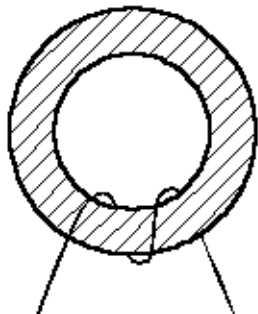

Table 2—L-Network Capacitor Information

| Capacitor Number | Target Value (pF) | Actual Value ($\pm 5\%$) (pF) | Capacitors (pF) |
|------------------|-------------------|---------------------------------|---------------------------|
| C54, C55 | 5 | 5 | 10 and 10 (in series) |
| C56 | 10 | 10 | 10 |
| C57, C58 | 20 | 20 | 10 and 10 (in parallel) |
| C59 | 40 | 39 | 39 |
| C60 | 80 | 82 | 82 |
| C61, C62 | 160 | 160 | 150 and 10 (in parallel) |
| C63, C64 | 320 | 320 | 220 and 100 (in parallel) |
| C65, C66 | 640 | 642 | 560 and 82 (in parallel) |

Note: All capacitors are 500-V units.

Microprocessor

U1, the microprocessor, is a *programmed* MC68HC11A1FN (see Note 1). The chip has 512 bytes of EEPROM for the assembly language program; 256 bytes of RAM for data storage; an 8-bit output port; an 8-bit input/output port; an 8-channel, 8-bit ADC input port and an 8-bit timer port. There's also a serial port (useful for RS-232-C applications) and a high-speed serial peripheral interface (SPI) port.

In the AT-11, the 8-bit output port is used for inductor control. The input/output port is configured as an 8-bit output port for

capacitor control (see **Table 3**). Only four of the eight inputs of the ADC are used: two for forward power, and two for reverse (each input uses two ports for averaging). The 8-bit timer port and four bits of port D are used to control the user interface and the HIGH/LOW-Z control. Four input bits of port D read the user switches and three output bits of port A control the LEDs.

The relays operate from 12 V dc. An on-board 78L05 regulator (U3) provides U1 with 5 V. U1's current consumption is about 10 mA. The total current drawn by the AT-11 depends primarily on the number of energized relays, with the maximum current drain being approximately 500 mA. U1 also needs a power supervisory circuit (U2, the 34064 IC) to provide a proper power-on sequence and to place U1 in a known reset mode while powering down. The powering-down protection is important because it keeps U1 from accidentally overwriting or erasing the internal EEPROM that contains the program. U2 also keeps U1 from "running away" if the operating voltage drops below 4.7 V.

Table 3—Digital Selection

| <i>Inductor Byte, K1-K8</i> | | <i>Capacitor Byte, K10-K17</i> | |
|------------------------------|-----------|--------------------------------|-----------|
| <i>Control Bits</i> | <i>μH</i> | <i>Control Bits</i> | <i>pF</i> |
| 1111 1111 | 19.92 | 1111 1111 | 1275 |
| 1111 1110 | 19.84 | 1111 1110 | 1270 |
| 1111 1101 | 19.76 | 1111 1101 | 1265 |
| .. | .. | .. | .. |
| .. | .. | .. | .. |
| 0000 0011 | 0.24 | 0000 0010 | 10 |
| 0000 0010 | 0.16 | 0000 0001 | 5 |
| 0000 0000 | 0.00 | 0000 0000 | 0 |
| <i>High/Low-Z Relay (K9)</i> | | | |
| 1 | High Z | | |
| 0 | Low Z | | |

Tuning Speed

I chose a crystal frequency of 4.433619 MHz over the more commonly available color-burst crystal frequency (3.59545 MHz) because the fundamental frequency and all harmonics fall outside the US HF amateur bands. If a 3.579-MHz color-burst crystal is all you have and you don't mind the possibility of hearing weak heterodynes on several bands, it will work fine with the AT-11.

Although the microprocessor's oscillator runs at 4.4 MHz, its internal bus speed is four times slower—1.1 MHz. This means that one instruction cycle executes in 0.9 ms. The main tuning routine takes about 75 cycles to make a tuner adjustment and take a new SWR measurement. This translates to 67.5 ms per tuner adjustment. If running at maximum speed, the 68HC11 can try all 131,072 LC combinations in just 8.8 seconds. Unfortunately, the mechanical relays can't react as quickly as the microprocessor, and the tuning speed must be slowed down to compensate for relay settling time.

The tuning routine, written in 68HC11 assembly language, uses an algorithm to minimize the number of tuner adjustments. The routine first ensures that the HIGH/LOW-Z relay is deenergized, then individually steps through the inductors to find a coarse match. With the best inductor selected, the tuner steps through the individual capacitors to find the best coarse match. If no match is found, the routine repeats the coarse tuning with the HIGH/LOW-Z relay energized. The routine then fine tunes the capacitors and inductors. The program checks every LC combination to see if a 1.5, or lower, SWR is obtained and stops when it finds a good match.

The number of tuner adjustments is between 4 and 288. There are 1 to 16 checks for the coarse inductor tuning, 1 to 16 for the coarse capacitor and between 2 and 256 for the inductor and capacitor fine tuning. With the speed reduced to 16 ms per selection to compensate for relay settling, the maximum tuning time is 6.1 seconds and the minimum tuning time is 0.06 second.

Generally, the farther away from resonance an antenna is from the transmitter's operating frequency, the longer it takes the tuner to find a match. Test results showed that my 40-meter 1/2-λ dipole tunes to any frequency in the band in less than half a second. Because the software stops when it finds an SWR of 1.5 or less, the manual switches can be used to fine-tune the match. Usually, only one or two push-button presses are required to move the SWR from 1.5 to 1.

User Interface and Operation

Power to the tuner is controlled by S6, the ON/OFF switch. S7 is the mode control (AUTO/SEMI) switch. Five momentary contact switches are available for manual operation and four LEDs monitor the SWR and tuning status.

Antenna tuning should be done with the transmitter set to a power output of about 10 W. The AT-11 will tune using the maximum input power level of 100 W, but using the lower power level prolongs relay-contact life and reduces the probability of false readings caused by stray RF from a high SWR. Because most solid-state radios automatically reduce their output power to about 10 W when a high SWR is present, no manual power adjustment is needed with them. Transmitters with vacuum-tube finals should have their power output level reduced to 10 W during tuning.

S6 also resets the microprocessor and bypasses the tuner (OFF is the bypass position). Turning on the tuner makes U2 send a reset command to the U1. This starts U1's internal program. The initialization section of the program includes an LED test. All four LEDs turn on for about 0.25 second, then extinguish to indicate that U1 has successfully started. The program then goes to the monitor loop where it checks the switches for input and updates the SWR LEDs.

In the AUTO mode, the tuner automatically runs the main tuning algorithm when it senses the presence of at least 2 W of forward power and an SWR of more than 3. If the tuner does not find a match, the tuning algorithm continues until power (RF, 12 V, or both) is removed, or the AUTO/SEMI switch is placed in the SEMI position.

In the SEMI mode, the TUNE push-button tells the microprocessor to run the main tuning algorithm. The program first checks for 2 W or more of forward power. If there's less than 2 W, all LEDs flash once to indicate that the pushbutton was acknowledged, but there is not enough power to tune accurately. Once in the tuning loop, the program finds the best match between the radio and antenna. Once the TUNE switch is pressed, the three SWR status lights provide you with a visual indication of the SWR. The LEDs flash frequently while different LC combinations are tried, as the tuner looks for the best match. Once the tuning algorithm is completed, the three LEDs give an indication of the final SWR achieved by the tuner. If the green LED (DS1) alone is lit, it indicates an SWR of less than 1.5; simultaneously illuminated green and yellow LEDs (DS1 and DS2) indicate an SWR between 1.5 and 2.0. If DS2 alone is lit, it indicates an SWR between 2.0 and 2.5. Lighted yellow and red LEDs (DS2 and DS3) indicate an SWR between 2.5 and 3.0. An SWR over 3 is indicated by DS3 only being lit. A second red LED (DS4) lights whenever the AT-11 is seeking a match. It's a good status indicator if the tuner is used remotely.

Once a low SWR (1.5 or less) is found, the program goes back to the monitor loop to keep the status of the SWR updated. This provides a visual indication of a change or problems in the antenna system. The SWR LEDs are lit only while more than 2 W of forward power is available. The manual UP and DOWN controls are used for fine-tuning the inductors and capacitors one step at a time (0.08 μ H for the inductors and 5 pF for capacitors). Pressing the CAP UP or IND UP switch increases capacitance or inductance, respectively. Pressing the CAP DOWN or IND DOWN switch decreases the capacitance or inductance, respectively.

The manual switches are good for touching up the match once the tuning algorithm has done its job. The UP and DOWN manual pushbuttons function in both modes: The auto and semi modes and are slowed down to about 0.25 second per adjustment. The lower limit of the DOWN switches can go only to "no components selected" and the upper limit of the UP switches can go only to "all components selected." If either limit is reached, all LEDs flash when the switch is pressed.



Figure 3—The neat and attractive front panel of the compact AT-11 belies its capabilities.

Construction Notes

A front view of the AT-11 prototype is shown in **Figure 3**. **Figure 4** takes a peek inside the tuner. I suggest you construct the tuner in a metal enclosure (a Radio Shack 270-272 is suitable). Place the L1 and L2 windings at the bottom of the T-106 toroid

(see the inset of **Table 1**). Space the windings of L3 through L8 evenly around the toroid as shown. Use the inductor chart (**Table 1**) to determine the proper length of the #18 wire before winding.

The 68HC11 is a CMOS microcontroller. Take standard antistatic precautions when handling the chip. Once in the socket, the IC is relatively protected. Use a well-regulated and RF-protected 12-V power supply. RF can become superimposed on the dc supply and cause problems with the tuning algorithm, latch-up or relay chatter. Bypass capacitors are located on the PC board, but they can't compensate for anything that happens at the power supply.

T1 is a bifilar wound transformer with 14 turns of #28 wire on an FT-37-43 ferrite toroid (see the inset of **Figure 2**). Use wires of different colors (or color-code them with spray paint or nail polish) to help identify the individual wires. If you connect the windings incorrectly, the calibration test-point voltages will be reversed.

Coaxial cable is not needed to bring RF on and off the board. Left-over #18 wire from the inductors can be used and acts as the primary for T1. Scrape away the paint around the SO-239 mounting holes to provide a good connection to the chassis. Also, run a wire from one of the bolts holding *each* of the SO-239s to the ground foil of the PC board. This ensures that the tuner's PC board also has a good ground connection.

Caution: Do not normally operate the tuner with the cover removed! During the tuning cycle, there are high voltages and/or currents present. Keep your fingers away from the toroids and any PC-board traces that carry RF. An RF burn, even at the 100-W level, can be painful.

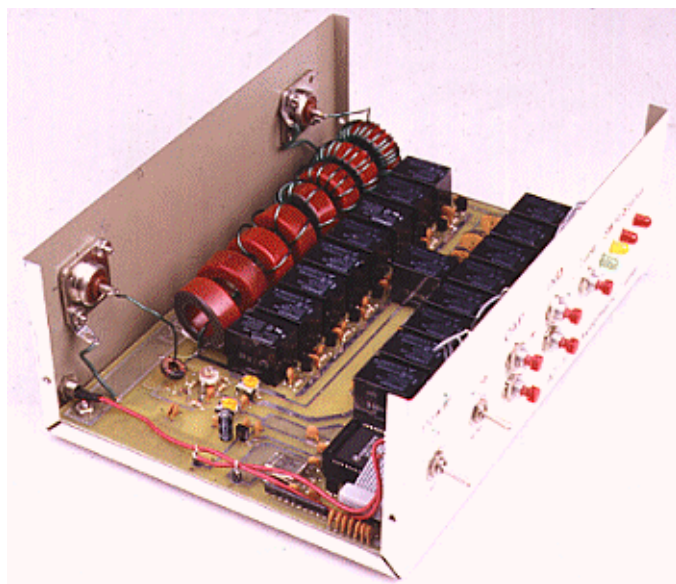

Figure 4—Inside, the double-sided PC board with plated-through holes helps make the AT-11 good-looking as well as functional.

Remote Operation

It's easy to operate the AT-11 remotely. Up to 10 signals are available from the tuner to bring to the user interface. Because this user interface consists only of dc connections to LEDs and switches (no RF signals; see **Figure 2**), the distance between the tuner and the user interface can be up to 10 feet or more. A 10-pin header on the PC board allows for easy plug-in of a remote cable (see the header pin layout, **Figure 2**). Not all of the wires may be necessary for your remote installation. You may want to run only the tuning indicator and the AUTO/SEMI switch. If you already have an SWR meter in your transceiver or transmitter, you probably won't need the three wires for the SWR LEDs. You can install the AT-11 at the base of a vertical or in the center of an inverted **V** or dipole. Be sure to weatherproof the installation to keep moisture from getting to the tuner.

When using the tuner remotely, the tuner's SWR indication may be different from the reading obtained at the transmitter end of the feed line. This is due to the longer length of feed line between the radio and tuner. If you must match for the lowest SWR reading at the transmitter, use the automatic tuning to get close, then use the manual switches to fine-tune while monitoring the SWR meter at the transmitter.

When using the tuner remotely with control-cable lengths greater than 10 feet, place an additional 0.01- μ F bypass capacitor

across each switch as close as possible to the microprocessor. This helps keep stray RF off the switch signals going to the microprocessor.

Adjustments

Only a few simple adjustments are needed to calibrate the SWR and power sensors. You'll need a transmitter, a dummy (or resonant) antenna and a dc voltmeter. Preset R53 and R54 to their center positions before calibration.

- Connect your transmitter's output to the tuner's input jack, J1, and connect a dummy antenna to the tuner's output jack, J2. Place the dc voltmeter probe on test point REV. While transmitting a steady carrier (using a power output of about 10 W), tune C1 for a minimum reading on the voltmeter. The reading should be close to zero. This completes the SWR circuit adjustment.

- To calibrate the forward-reading wattmeter section, connect your transmitter's output to the tuner's input jack (J1) and connect a dummy antenna to the tuner's output jack (J2). Place the voltmeter probe on test point FWD. Set the transmitter's power output level to 100 W and adjust R53 for a 4.5 V reading on the voltmeter. If you're transmitting at a power level of 100 W, the SWR is fairly low (less than 2) and you can't get a 4.5-V reading, you may have T1's windings connected incorrectly. If they are connected incorrectly, you'll read near 0 V at test point FWD and around 5 V at test point REV with R53 and R54 in their center positions. If you can't get 100 W out of your transmitter, set its power level to 10 W and follow the foregoing calibration procedure to obtain a reading of 1.5 V on the voltmeter.

- To calibrate the reverse-reading wattmeter section, connect the transmitter to the output jack (J2) and connect the dummy antenna to the input jack (J1). Place the voltmeter probe on test point REV. Adjust the transmitter to provide 100 W output and adjust R54 to read 4.5 V on your voltmeter. If you can't get 100 W out of your transmitter, set its power-output level to 10 W and adjust R54 for 1.5 V. This completes the power meter adjustment. The tuner's now ready for action.

Performance

I thoroughly tested the AT-11 at my station with Kenwood TS-440-AT and Kenwood TS-820S transceivers, using dipoles, verticals and other antennas. The tuner performed much better than the internal tuner of my TS-440—and most times found a match much faster. The AT-11 tuned my 40-meter dipole to *all* of the amateur bands from 80 through 10 meters (it couldn't tune the dipole on 160 meters), while my transceiver's internal tuner found a match on only 50% of the bands!

Most of Frank Witt's procedures from his *QST* article were used to evaluate the AT-11. [4] The tuner has an average SWR bandwidth of about 200 kHz. An Autek Research RF-1 RF Analyst showed that the AT-11 can match resistive loads of about 10 to 500 Ω (SWR of 8) on all the low bands except 160 meters, where it could match only 25 to 100- Ω loads (SWR of 2).

Although there are limitations encountered by the use of discrete components as compared to using continuously variable components, the 131,072 possible combinations will find a usable match for most unbalanced antenna systems.

Acknowledgments

I want to express my thanks to the members of the Southern Patuxent Amateur Radio Club for providing the test bed and feedback for this project. Special thanks to Gene Tehansky, AA3AV, for his contributions and assistance with the assembly language and PC-board layout. Also thanks to Phil Lane, N3RDP; Glenn Thorn, KE3MF; and Nick Gravelle, N3JDG, for their assistance with the prototypes, and Randy Norris, KE3QZ, for help with testing. And thanks to my wife, Jennifer, for her patience, understanding and support with this project.

Dwayne Kincaid, 1445 Parran Road, St Leonard, MD 20685, was licensed in 1977 at the age of 16. He holds a BS degree in electrical engineering from West Virginia Tech and is currently an employee at the Naval Air Warfare Center, Aircraft Division, at Patuxent River, MD.

Notes

¹A complete parts kit of all components including a *programmed* 68HC11 (less power supply and enclosure) is available for \$150, plus \$8 shipping (US and Canada) from LDG Electronics, 1445 Parran Rd, St Leonard, MD 20685, tel 410-586-2177; MasterCard and VISA accepted. (Source code is not available.) Foreign orders add \$20 for postage. Maryland residents must add 5% sales tax. A drilled and etched PC board is available for \$35, plus \$5 shipping. A programmed 68HC11 with socket is available for \$20, plus \$5 shipping.

²Doug DeMaw, W1FB, *W1FB's QRP Notebook* (Newington: ARRL, 1991), 2nd edition. ARRL publication #3657, available from

your local ham radio store and the ARRL (see the *ARRL Publications Catalog* in this issue of *QST*).

³Wilfred N. Caron, *Antenna Impedance Matching* (Newington: ARRL, 1989). ARRL publication #2200. Price: \$20.

⁴Frank Witt, AI1H, "How to Evaluate Your Antenna Tuner,"—*Part 1*, *QST*, Apr 1995, pp 30 to 34; —*Part 2*, May 1995, pp 33-37.